



1 1/8" Channel

Telestrut

Nuts & Hardware

General Fittings

Pipe/Conduit Supports

Electrical Fittings

Concrete Inserts

Solar

Unipier®

P2820, P2940 CHANNEL/TUBE CONNECTORS

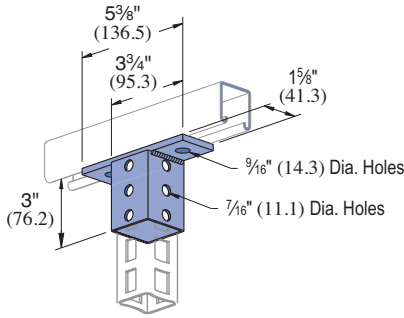

| Part No. | Use With | Wt/100 pcs Lbs (kg) |
|----------|----------|---------------------|
| P2820 | P16F | 116 (2.6) |
| P2940 | P21H | 148 (67.1) |

P2822, P2932

SPLICE FITTINGS

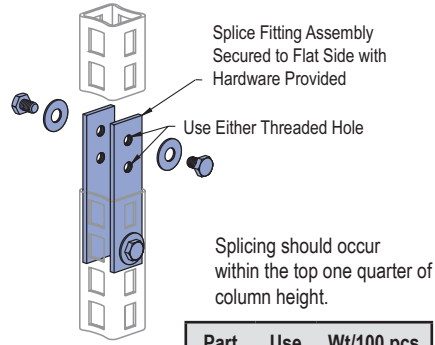

| Part No. | Use With | Wt/100 pcs Lbs (kg) |
|----------|----------|---------------------|
| P2822 | P16F | 97 (44.0) |
| P2932 | P21H | 122 (55.3) |

P2823

90° RACK FITTING

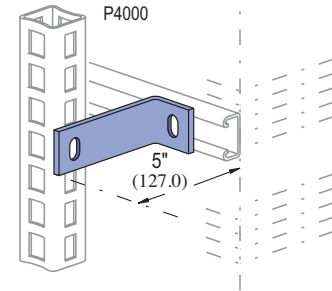

Wt/100 pcs: 66 Lbs (29.9 kg)

P2821

LOCKING CLIP

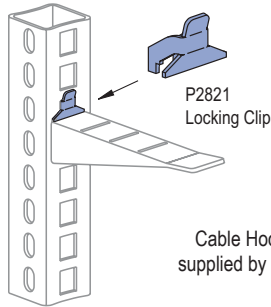

Cable Hook supplied by others.

Exclusive Cable Hook
Locking Clip prevents Cable Hook removal.

Wt/100 pcs: 3 Lbs (1.4 kg)

P2928, P2929 AND P2930

CABLE BRACKETS

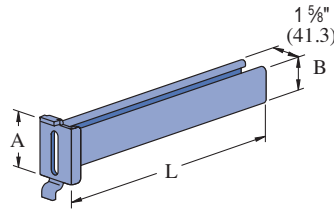

Use with P16F or P21H.

Material: 12 gauge steel.

| Part Number | "L" In (mm) | "A" In (mm) | "B" In (mm) | Wt/100 pcs Lbs (kg) | Uniform Design Load Lbs (kN) |
|-------------|-------------|--------------|--------------|---------------------|------------------------------|
| P2928 | 6 / 152.4 | 3 1/2 / 88.9 | 7/8 / 22.2 | 92 / 41.7 | 500 / 2.22 |
| P2929 | 12 / 304.8 | 3 1/2 / 88.9 | 1 5/8 / 41.3 | 320 / 145.1 | 250 / 1.11 |
| P2930 | 18 / 457.2 | 3 1/2 / 88.9 | 1 5/8 / 41.3 | 420 / 190.5 | 170 / 0.76 |

Safety factor of 3.

P2920 THRU P2924

CABLE BRACKETS

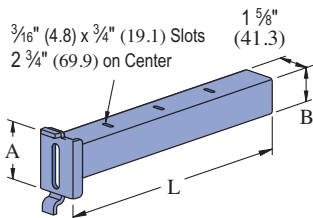

Use with P16F or P21H.

Material: 12 gauge steel.

| Part Number | "L" In (mm) | "A" In (mm) | "B" In (mm) | Wt/100 pcs Lbs (kg) | Uniform Design Load Lbs (kN) |
|-------------|----------------|--------------|--------------|---------------------|------------------------------|
| P2920 | 5 1/2 / 139.7 | 3 1/2 / 88.9 | 7/8 / 22.2 | 90 / 40.8 | 500 / 2.22 |
| P2921 | 8 1/4 / 209.6 | 3 1/2 / 88.9 | 7/8 / 22.2 | 120 / 54.4 | 325 / 1.45 |
| P2922 | 11 / 279.4 | 3 1/2 / 88.9 | 1 5/8 / 41.3 | 300 / 136.1 | 275 / 1.22 |
| P2923 | 13 3/4 / 349.3 | 3 1/2 / 88.9 | 1 5/8 / 41.3 | 340 / 154.2 | 220 / 0.98 |
| P2924 | 19 1/4 / 489.0 | 3 1/2 / 88.9 | 1 5/8 / 41.3 | 430 / 195.0 | 160 / 0.71 |

Safety factor of 3.